

MORI dMEV II

DE-CENTRALISED MECHANICAL EXTRACT VENTILATION FAN



RESIDENTIAL PRODUCT INFORMATION

MORI dMEV II

DE-CENTRALISED MECHANICAL EXTRACT VENTILATION FAN

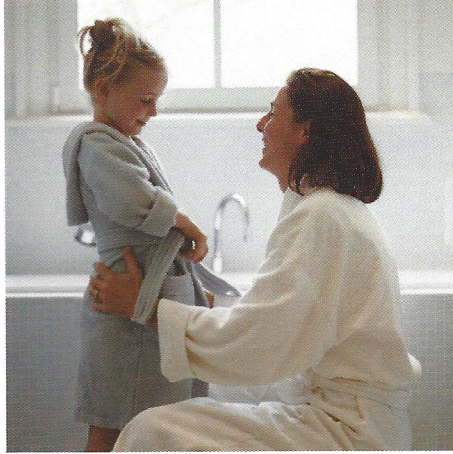

APPLICATION

A choice of two continuously running, low energy, ultra quiet extract fans for use in kitchens, utility rooms, bathrooms, shower rooms, en-suites and toilets.

Unlike conventional intermittent operating extract fans, continuously running extract fans like the **MORI dMEV II** range do not have a high dependency on background ventilators (e.g. trickle vents in windows) to effectively ventilate a dwelling. In more airtight homes, they will generally require less background ventilators than intermittent operating fans and in less airtight homes, they are unlikely to require any at all. The low dependency on background ventilators combined with extremely low noise levels and running costs, and a wide range of controls and duties to suit various applications, has resulted in the **MORI dMEV II** range of fans becoming the first choice extract fan range for an increasing number of customers throughout the UK and Ireland.

SUITABLE FOR BATHROOMS, SHOWERS, EN-SUITES, UTILITIES & KITCHENS

ULTRA QUIET
VERY LOW RUNNING COSTS
REGULATORY COMPLIANT
WIDE OPERATING RANGE

OPERATION

MORI dMEV II HT

This unit has 3 conventional flow Background/Trickle speed settings to choose from on site. Comfort Boost flow rate is activated by an integral adjustable humidistat. The Comfort Boost flow rate is approximately half way between the pre-set Background and Boost flow rates. Boost flow rate is activated via the integral pull cord or an external switch via a switched live connection inside the fan. The unit has an adjustable Boost run on timer which is only triggered when Boost has been activated for over 60 seconds to prevent unintentional boost run on.

MORI dMEV II T

This unit has 3 Conventional flow Background/Trickle speed settings to choose from on site. Boost flow rate is activated via the integral pull cord or an external switch via a switched live connection inside the fan. The unit has a similar Boost run on timer facility to the MORI dMEV II HT unit.

FEATURES / BENEFITS

Regulatory compliant Complies with all UK building regulation requirements.

Extremely low power consumption Annual running costs of as little as £1 per year for continuous operation.

Ultra quiet Almost imperceptible noise levels on lower Background settings.

Aesthetically pleasing front cover Blends in well with different wall and ceiling finishes.

Highly flexible Suitable for wall, ceiling or window mounting.

Wide application range 3 Background settings to choose from. Humidistat control option available on MORI dMEV II HT model.

Resilient Suitable for ambient temperatures up to 50°C.

IPX4 splash proof Suitable for installation in Zones 1 and 2. Kit required if ceiling mounted.

Double insulated No earth connection required.

Rigorously tested to relevant standards Each fan is individually tested prior to leaving the factory.

Warranty Each MORI dMEV II has a FIVE year warranty as standard.*



IPX4 RATED
SPLASHPROOF

TOTALLY
RECYCLABLE

5 YEAR
WARRANTY

PERFORMANCE DATA

Performance curve	Airflow L/s	Power W max	Sound Pressure dB(A) @ 3m	Ambient Temperature °C max
1	6	1	11	50
2	8	1.2	13	
3	13	1.7	23	
4	Boost - 23	2.5	26	

220-240V. 50Hz. Air performance measured according to ISO 5801.
MORI dMEV II HT - Energy rating: C. MORI dMEV II T - Energy rating: E.

PERFORMANCE CURVES

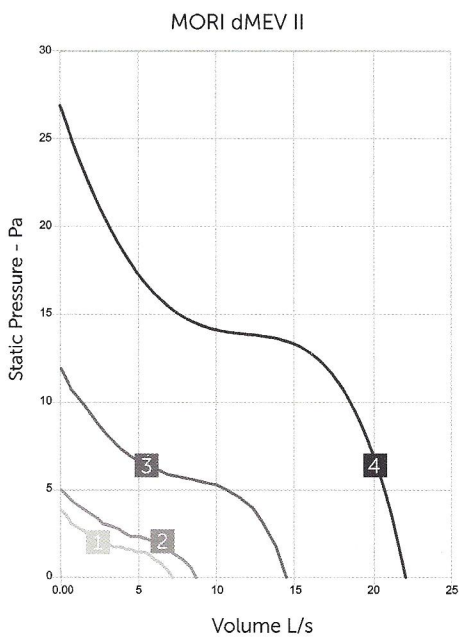

DIMENSIONAL DATA

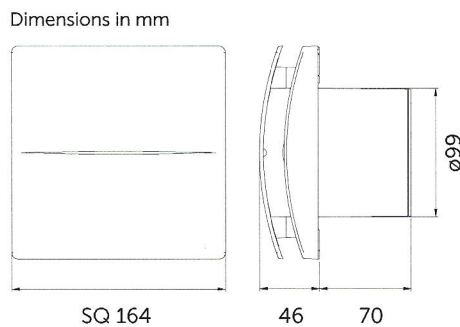

ACCESSORIES



Window Kit with
External Fixed Grille
410-WKG100

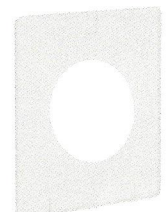

Ceiling Mount Kit
410-CG100

A full range of ancillaries and ducting are available for this product. Please contact us for more details.

MORI dMEV II

DE-CENTRALISED MECHANICAL EXTRACT VENTILATION FAN

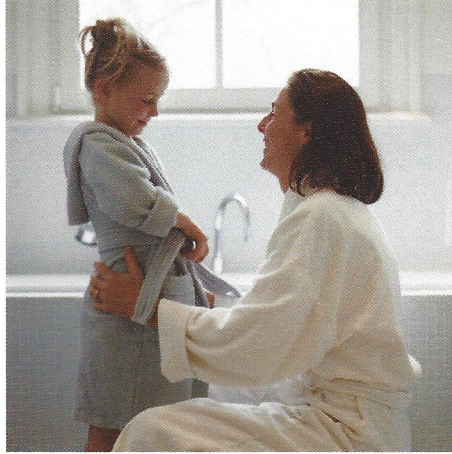

APPLICATION

A choice of two continuously running, low energy, ultra quiet extract fans for use in kitchens, utility rooms, bathrooms, shower rooms, en-suites and toilets.

Unlike conventional intermittent operating extract fans, continuously running extract fans like the **MORI dMEV II** range do not have a high dependency on background ventilators (e.g. trickle vents in windows) to effectively ventilate a dwelling. In more airtight homes, they will generally require less background ventilators than intermittent operating fans and in less airtight homes, they are unlikely to require any at all. The low dependency on background ventilators combined with extremely low noise levels and running costs, and a wide range of controls and duties to suit various applications, has resulted in the **MORI dMEV II** range of fans becoming the first choice extract fan range for an increasing number of customers throughout the UK and Ireland.

SUITABLE FOR BATHROOMS, SHOWERS, EN-SUITES, UTILITIES & KITCHENS

ULTRA QUIET
VERY LOW RUNNING COSTS
REGULATORY COMPLIANT
WIDE OPERATING RANGE

OPERATION

MORI dMEV II HT

This unit has 3 conventional flow Background/Trickle speed settings to choose from on site. Comfort Boost flow rate is activated by an integral adjustable humidistat. The Comfort Boost flow rate is approximately half way between the pre-set Background and Boost flow rates. Boost flow rate is activated via the integral pull cord or an external switch via a switched live connection inside the fan. The unit has an adjustable Boost run on timer which is only triggered when Boost has been activated for over 60 seconds to prevent unintentional boost run on.

MORI dMEV II T

This unit has 3 Conventional flow Background/Trickle speed settings to choose from on site. Boost flow rate is activated via the integral pull cord or an external switch via a switched live connection inside the fan. The unit has a similar Boost run on timer facility to the MORI dMEV II HT unit.

FEATURES / BENEFITS

Regulatory compliant Complies with all UK building regulation requirements.

Extremely low power consumption Annual running costs of as little as £1 per year for continuous operation.

Ultra quiet Almost imperceptible noise levels on lower Background settings.

Aesthetically pleasing front cover Blends in well with different wall and ceiling finishes.

Highly flexible Suitable for wall, ceiling or window mounting.

Wide application range 3 Background settings to choose from. Humidistat control option available on MORI dMEV II HT model.

Resilient Suitable for ambient temperatures up to 50°C.

IPX4 splash proof Suitable for installation in Zones 1 and 2. Kit required if ceiling mounted.

Double insulated No earth connection required.

Rigorously tested to relevant standards Each fan is individually tested prior to leaving the factory.

Warranty Each MORI dMEV II has a FIVE year warranty as standard.*